

SLR/SUR-246P

automatic loader / unloader



(Actual product might differ from image shown)

PCB

Automation

Developed

SUITABLE FOR

loading and unloading of
various processes without
soldermask

DESCRIPTION

SLR / SUR-246P

- 1 The SLR/SUR-246P can work with various carriers or boxes in different preset angles.
- 2 The machine includes a buffer for interleaf sheet handling.
- 3 The gripper picks and places the panels from racks or boxes with fast and precise positioning.
- 4 An advanced mechanism with additional sensors avoids warping of the panels during alignment.
- 5 The 12 suction cups can be adjusted either individually or by row to ensure optimum panel handling.

SAA

Symtek Automation Asia

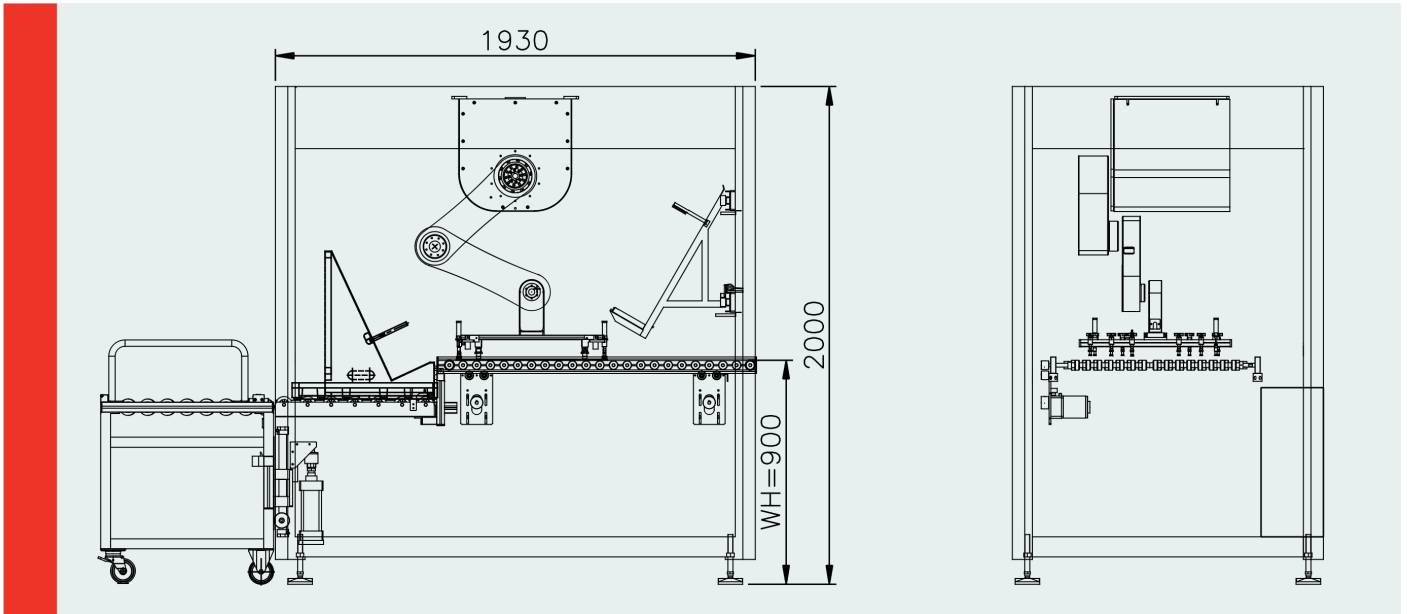

TYPE SLR/SUR-246P	Loader	Unloader
DIMENSIONS (LxWXH)	1930x1250x2000 mm	1930x1250x2000 mm
WORKING HEIGHT	900 mm ± 50mm	900 mm ± 50mm
MAX. PANEL SIZE	24x24 in.	24x24 in.
MIN. PANEL SIZE	12x12 in.	12x12 in.
PANEL THICKNESS	0.075 ~ 1.6 mm	0.075 ~ 1.6 mm
POWER	1PH 220V 50/60Hz 6KW	1PH 220V 50/60Hz 6KW
AIR	0.6 MPa 20 NL/min	0.6 MPa 20 NL/min
THROUGHPUT	5 pcs/min	5 pcs/min